

Type 3 - LE_86/148

86" X 148" Sprinter 3500 144" WB chassis, 72" Headroom

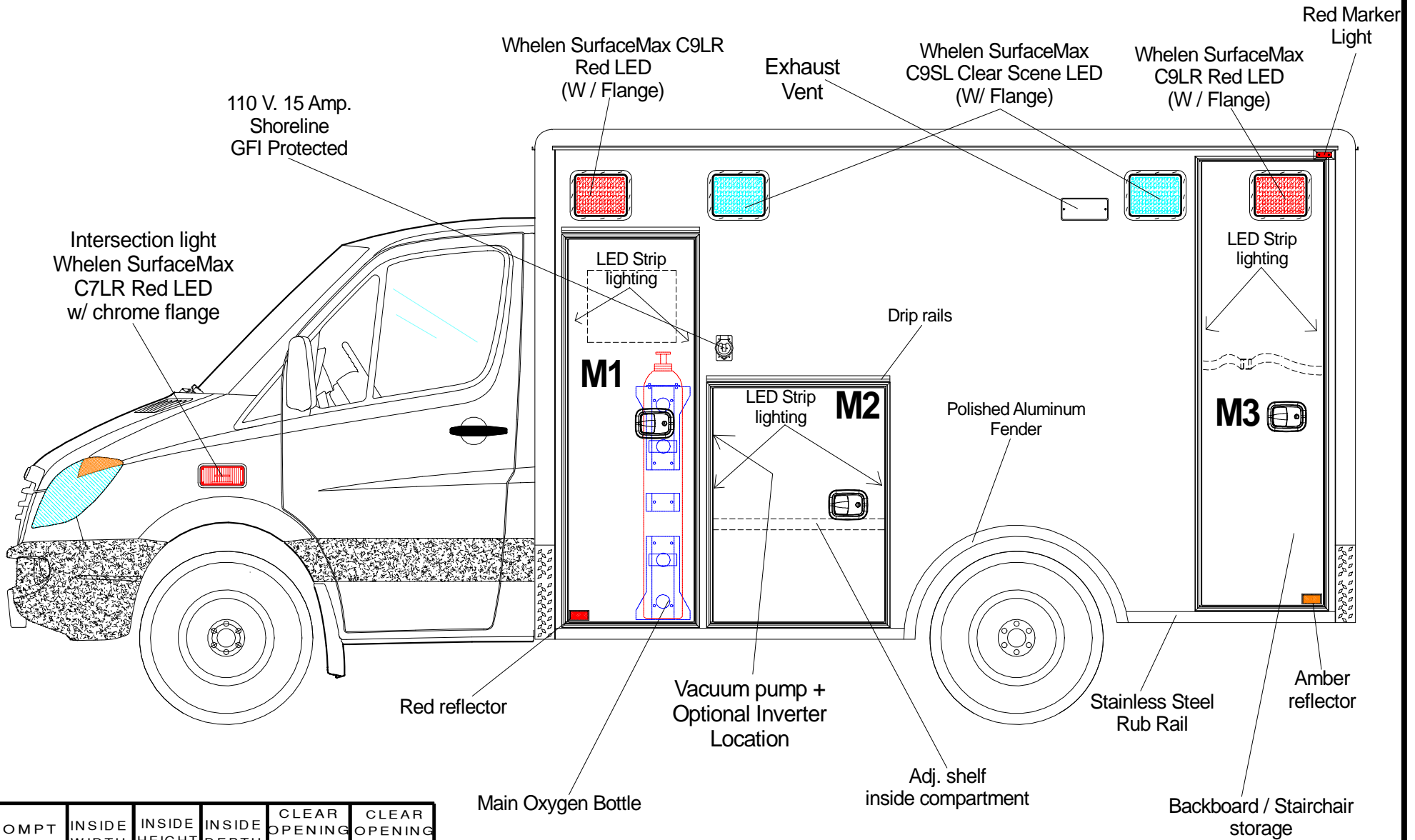

COMPT	INSIDE WIDTH	INSIDE HEIGHT	INSIDE DEPTH	CLEAR OPENING WIDTH	CLEAR OPENING HEIGHT
M1	24.95	69.375	15.48	22	68.165
M2	34	44.75	15.48	30.25	41.375
M3	26	82.545	15.48	21.24	79.165

Note: All dimensions are approximate and subject to change.
 10941 Weaver Ave., So. El Monte, CA 91733 phone. (626) 575-0880

VIEW: Streetside Exterior

Drawn by: Jorge M.

LE- 1



Type 3 - LE 86/148

86" X 148" Sprinter 3500 144" WB chassis, 72" Headroom

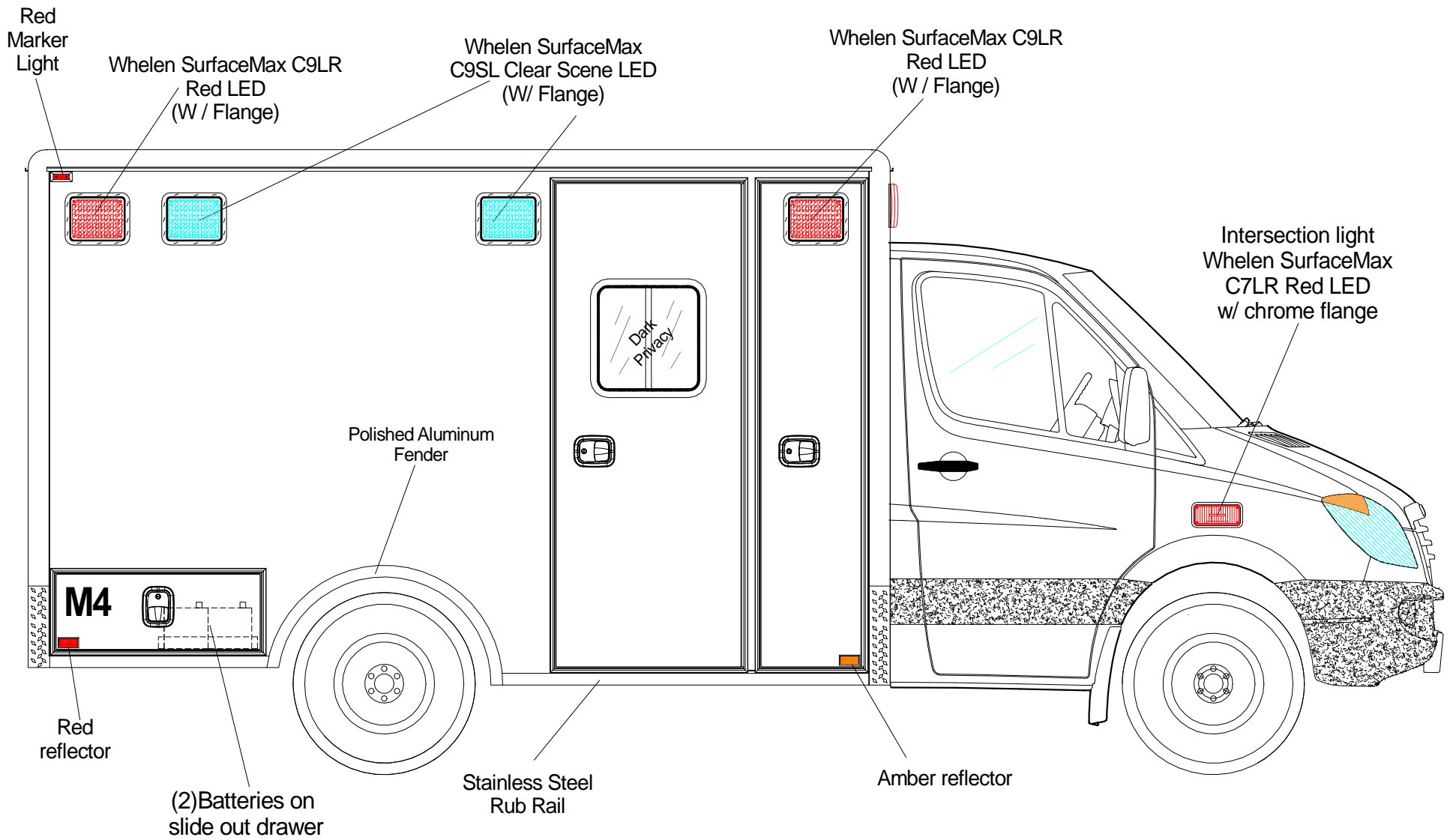

COMPT	INSIDE WIDTH	INSIDE HEIGHT	INSIDE DEPTH	CLEAR OPENING WIDTH	CLEAR OPENING HEIGHT
M4	37.30	13.00	15.48	31.125	12.00
M5				16.50	82.125

Note: All dimensions are approximate and subject to change.
10941 Weaver Ave., So. El Monte, CA 91733 phone. (626) 575-0880

VIEW: Curbside Exterior

Drawn by: Jorge M.

LE- 2



Type 3 - LE 86/148

86" X 148" Sprinter 3500 144" WB chassis, 72" Headroom

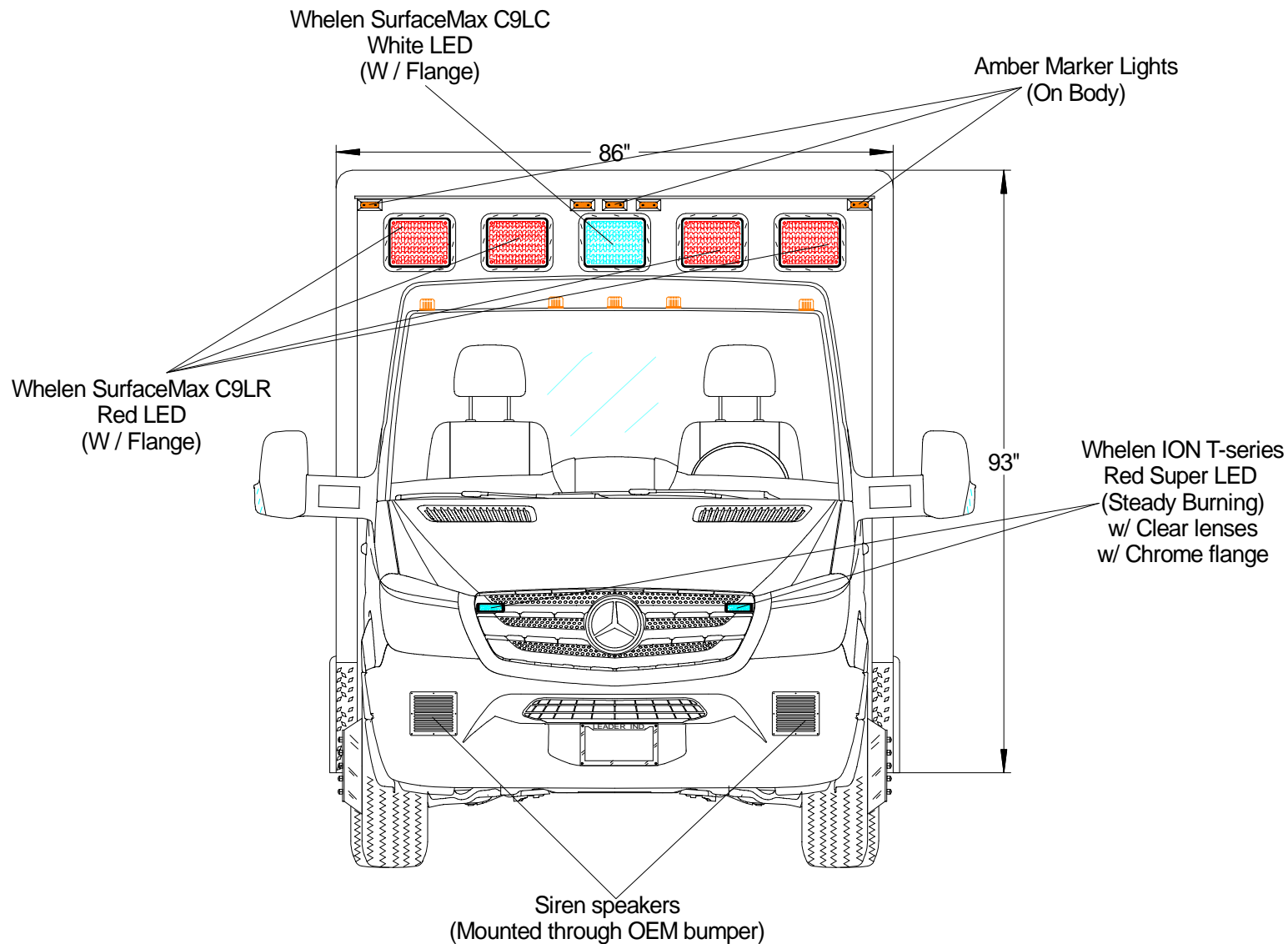

Note: All dimensions are approximate and subject to change.

10941 Weaver Ave., So. El Monte, CA 91733 phone. (626) 575-0880

VIEW: Front Exterior

Drawn by: Jorge M.

LE- 3



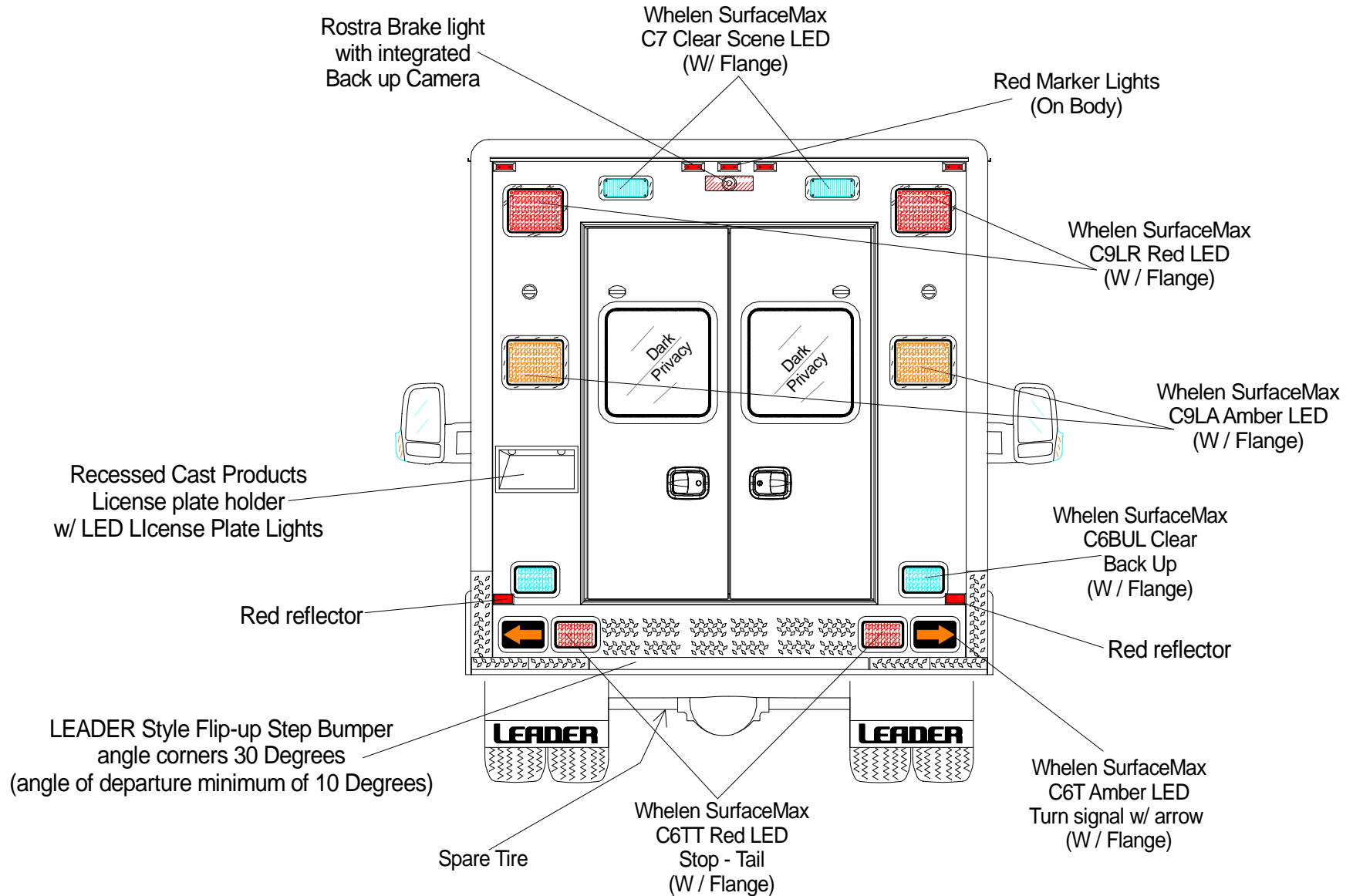

Note: All dimensions are approximate and subject to change.
10941 Weaver Ave., So. El Monte, CA 91733 phone. (626) 575-0880

Type 3 - LE 86/148

86" X 148" Sprinter 3500 144" WB chassis, 72" Headroom

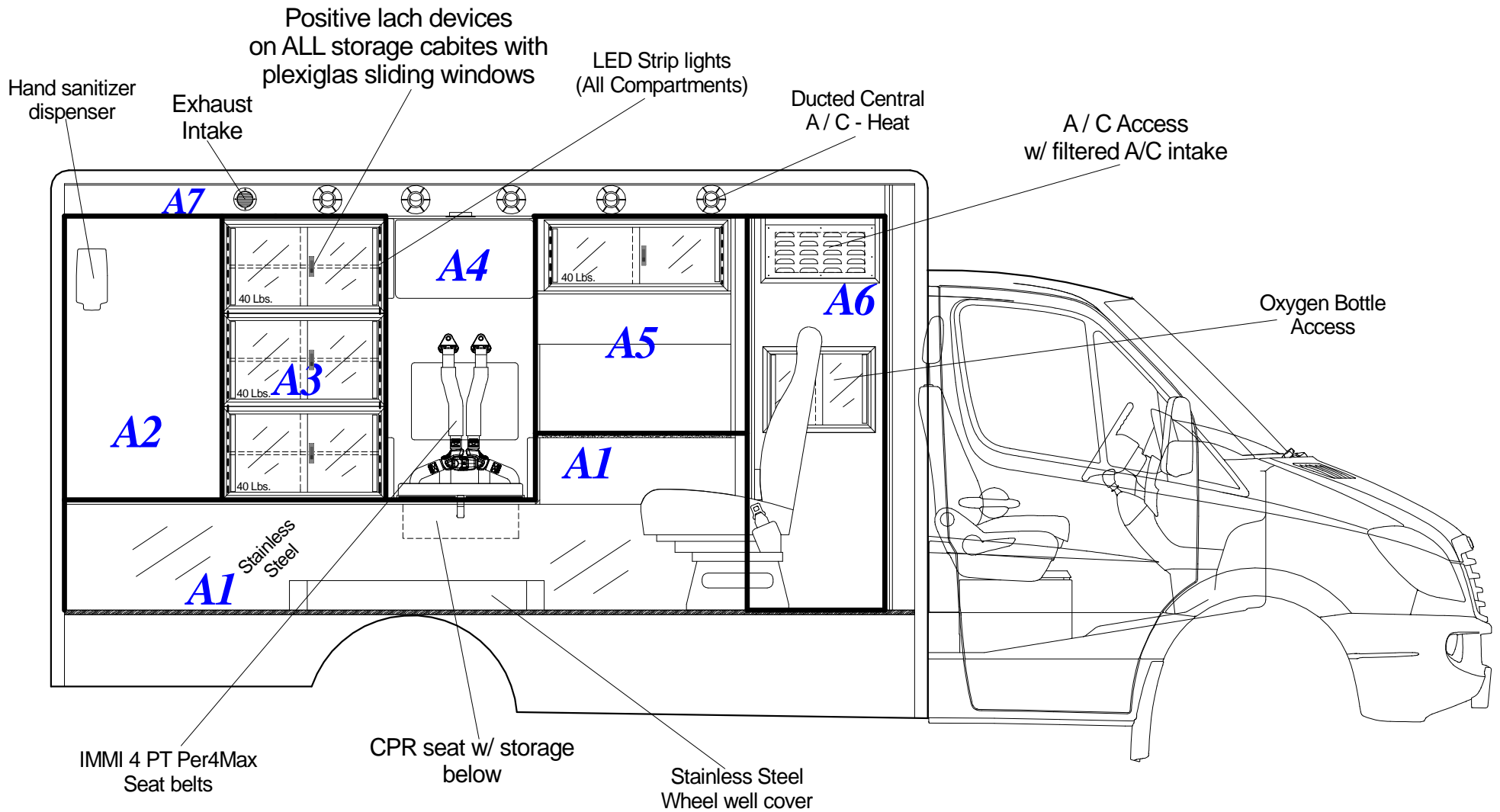

WHITE GLOSS LAMINATE

Note: All dimensions are approximate and subject to change.
10941 Weaver Ave., So. El Monte, CA 91733 phone. (626) 575-0880

VIEW: Streetside Interior

Drawn by: Jorge M.

LE- 5



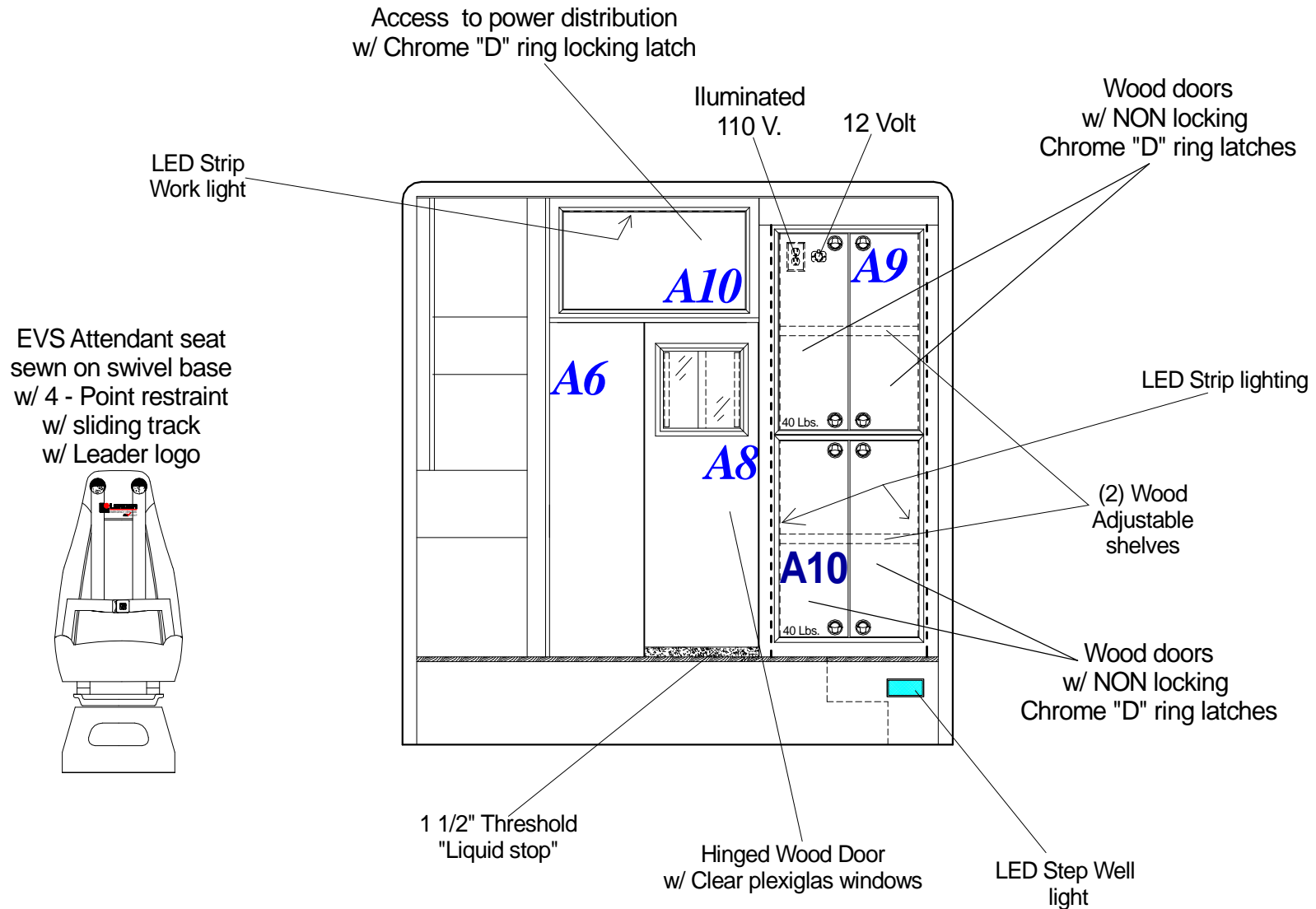

Note: All dimensions are approximate and subject to change.
10941 Weaver Ave., So. El Monte, CA 91733 phone. (626) 575-0880

Type 3 - LE 86/148

86" X 148" Sprinter 3500 144" WB chassis, 72" Headroom

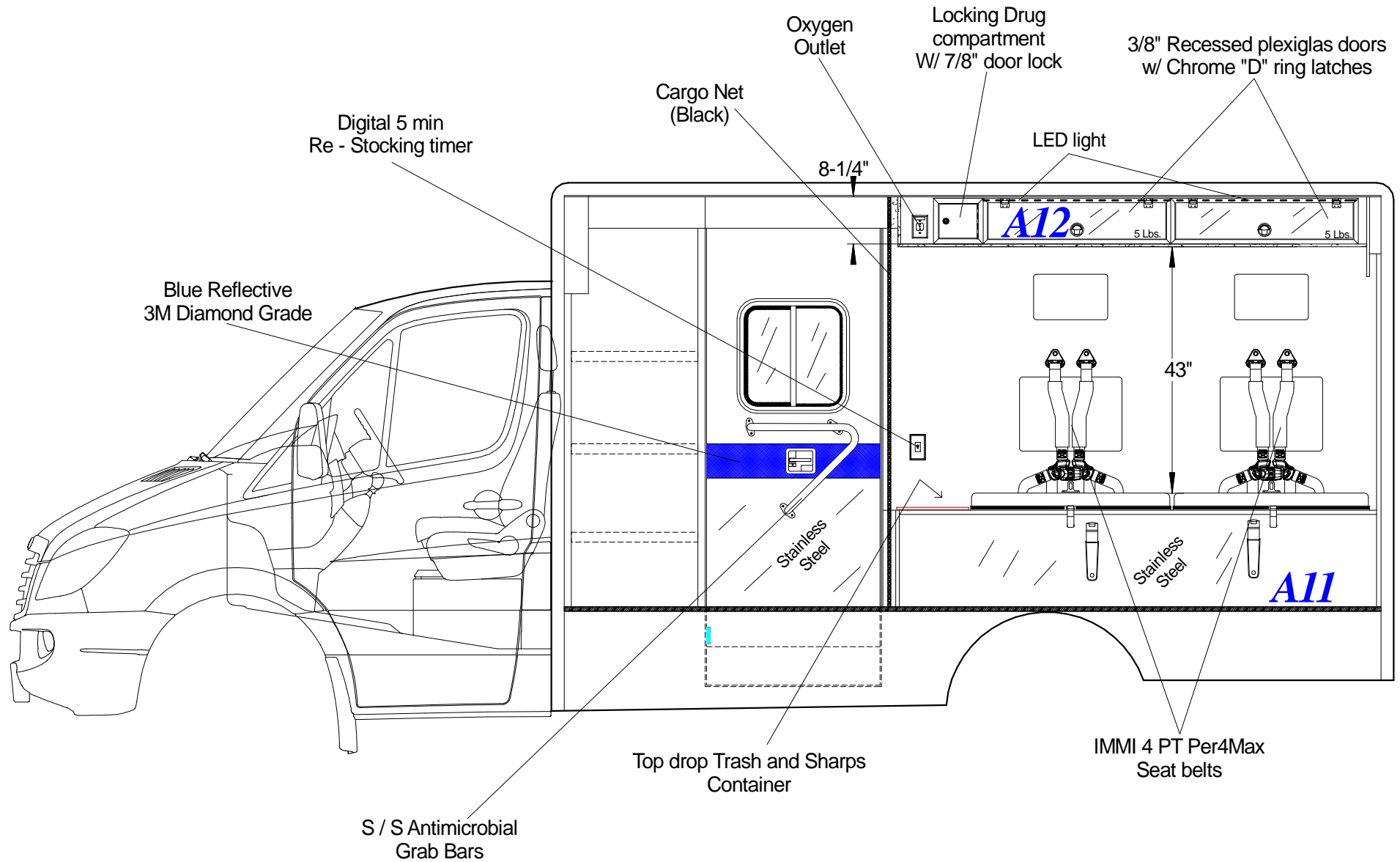

Note: All dimensions are approximate and subject to change.
10941 Weaver Ave., So. El Monte, CA 91733 phone. (626) 575-0880

VIEW: Curbside Interior

Drawn by: Jorge M.

LE-7



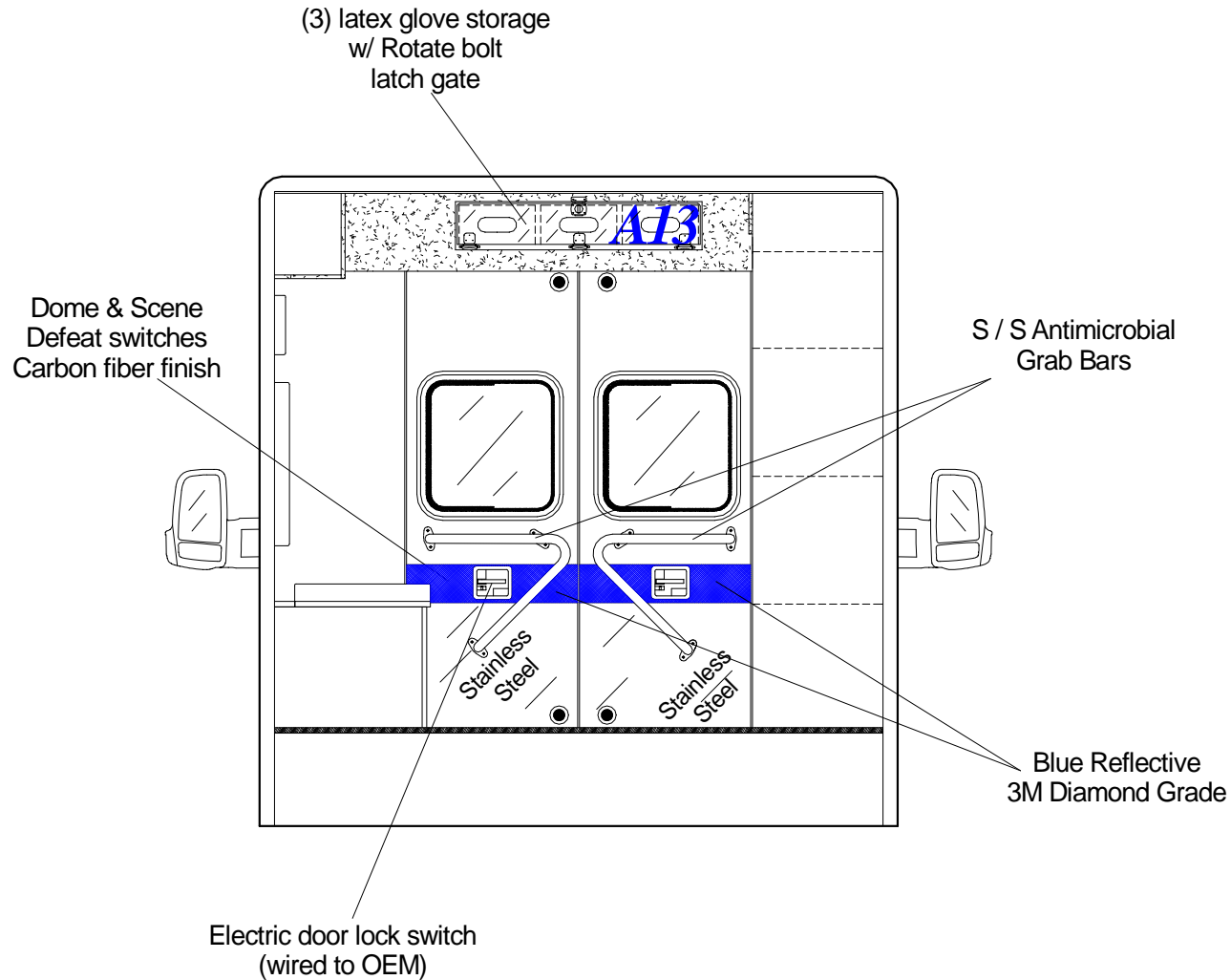

Note: All dimensions are approximate and subject to change.

10941 Weaver Ave., So. El Monte, CA 91733 phone. (626) 575-0880

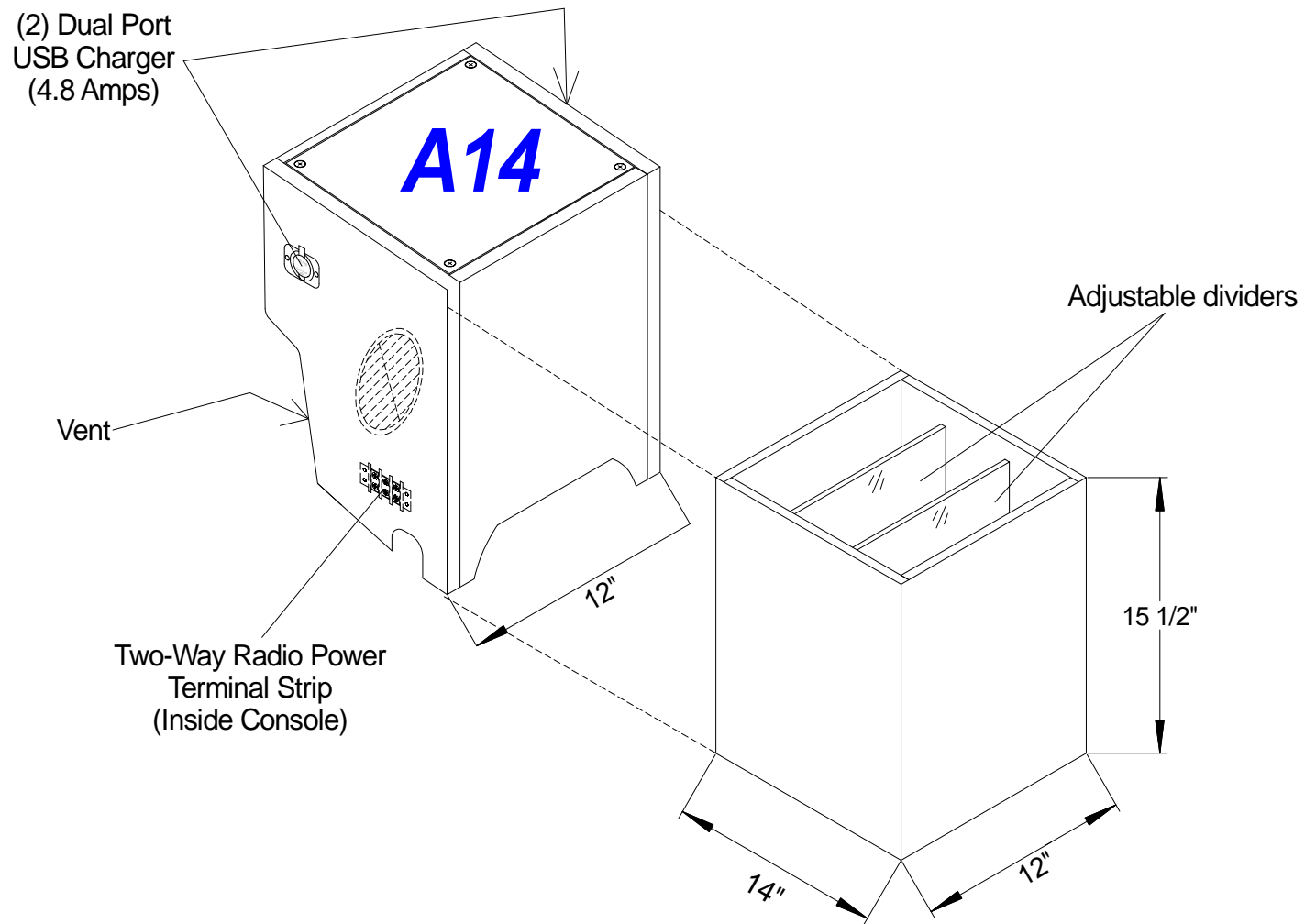

Note: All dimensions are approximate and subject to change.
10941 Weaver Ave., So. El Monte, CA 91733 phone. (626) 575-0880

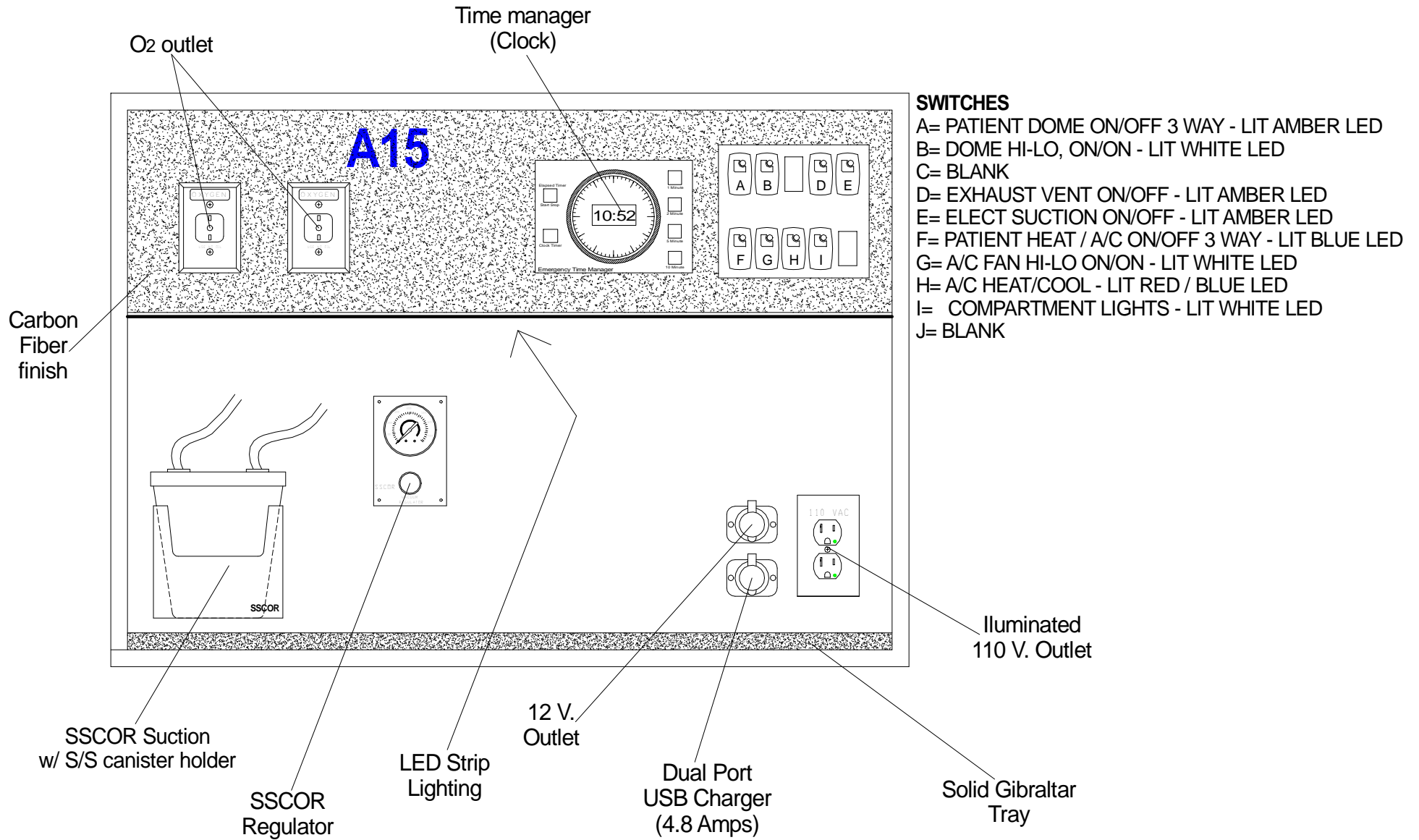

Note: All dimensions are approximate and subject to change.
 10941 Weaver Ave., So. El Monte, CA 91733 phone. (626) 575-0880

SWITCHES

- A. PRI- SEC- LIT RED/ AMBER LED
(SIREN ACTIVATED PRIMARY ONLY)
- B. BLANK
- C. BLANK
- D. BACK UP ALARM-RESET TYPE-MOM. ON (NON LIT)
- E. LEFT SCENE WHITE LIT LED
- F. REAR SCENE WHITE LIT LED
- G. RIGHT SCENE WHITE LIT LED
- H. PATIENT DOME 3-WAY - LIT AMBER LED
- I. PATIENT HEAT A/C 3-WAY - LIT BLUE LED
- J. MOD. DISCONNECT - GREEN LIT LED
- K. BLANK
- L. DIMMER KNOB
- M. EMERGENCY START, ON-OFF GUARDED (NON LIT)

PILOT LIGHTS

- N. PILOT LIGHT - EMERGENCY START RED LED
- O. PILOT LIGHT - MASTER ON GREEN LED
- P. PILOT LIGHT - DOOR OPEN RED LED
- Q. PILOT LIGHT - COMP. OPEN AMBER LED
- R. PILOT LIGHT - PARKING BRAKE RED LED
- S. PILOT LIGHT - LOW VOLTAGE AMBER LED

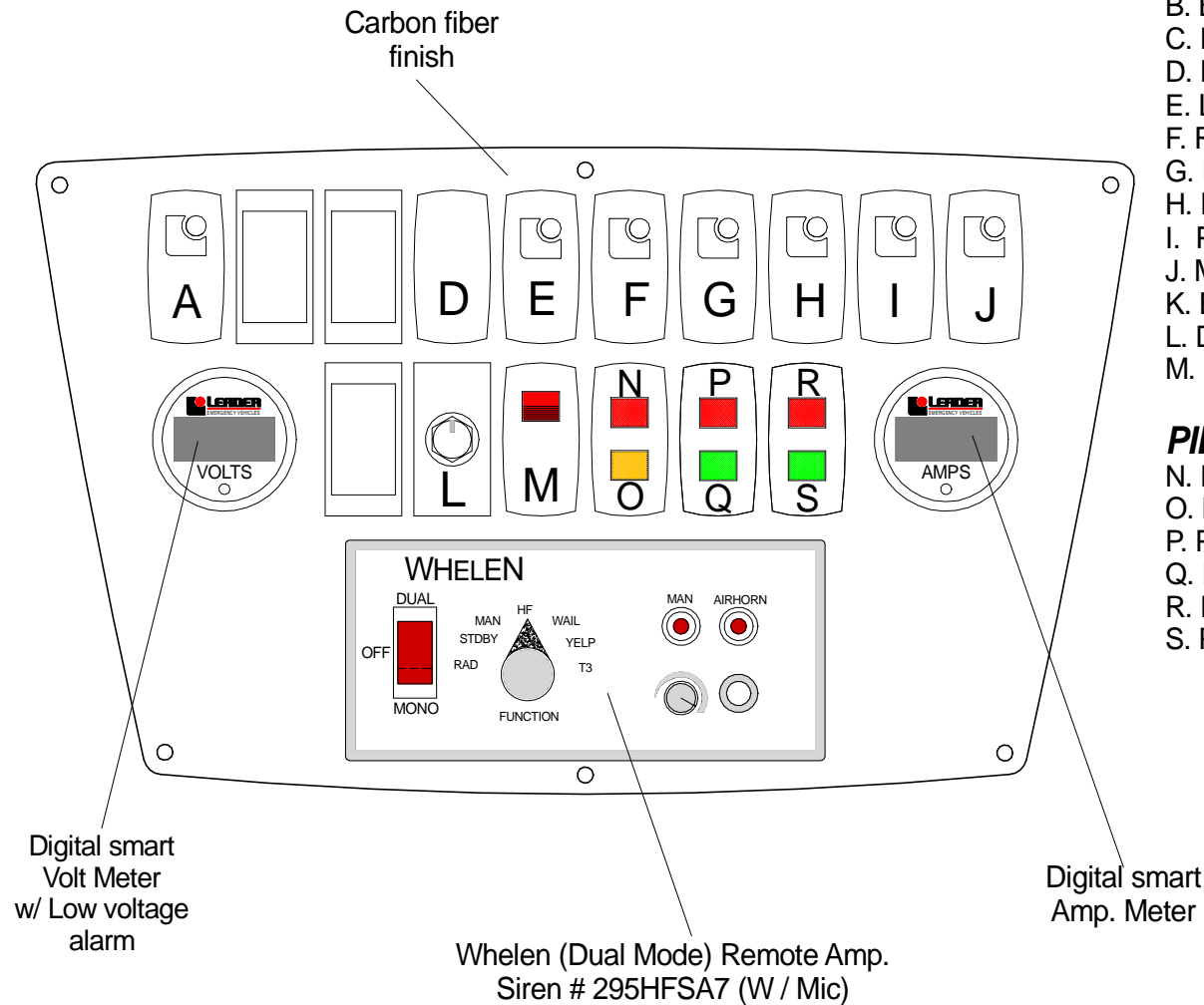

Note: All dimensions are approximate and subject to change.

10941 Weaver Ave., So. El Monte, CA 91733 phone. (626) 575-0880

Type 3 - LE 86/148

86" X 148" Sprinter 3500 144" WB chassis, 72" Headroom

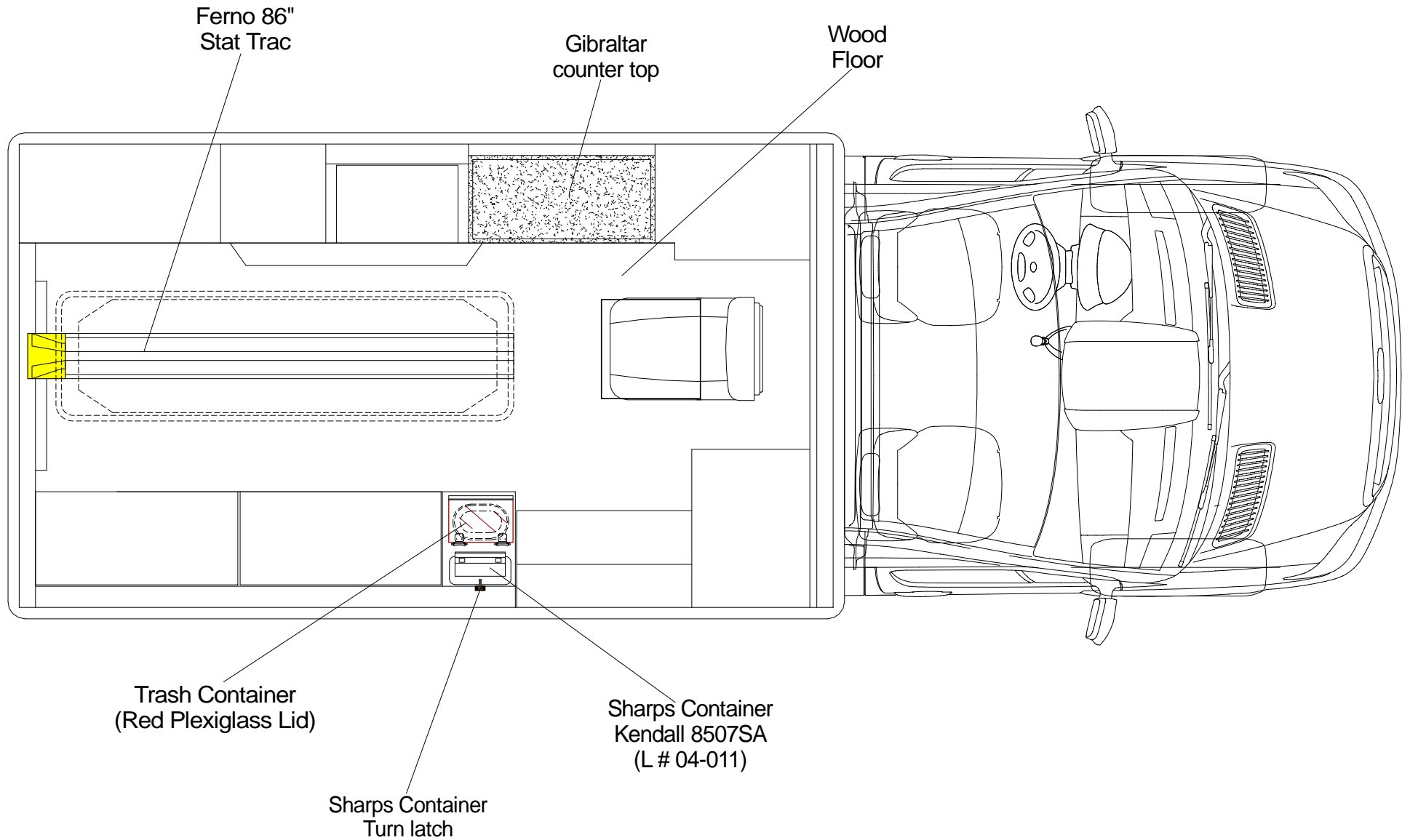

Note: All dimensions are approximate and subject to change.
10941 Weaver Ave., So. El Monte, CA 91733 phone. (626) 575-0880

VIEW: Overhead Floor

Drawn by: Jorge M.

LE-12



Type 3 - LE 86/148

86" X 148" Sprinter 3500 144" WB chassis, 72" Headroom

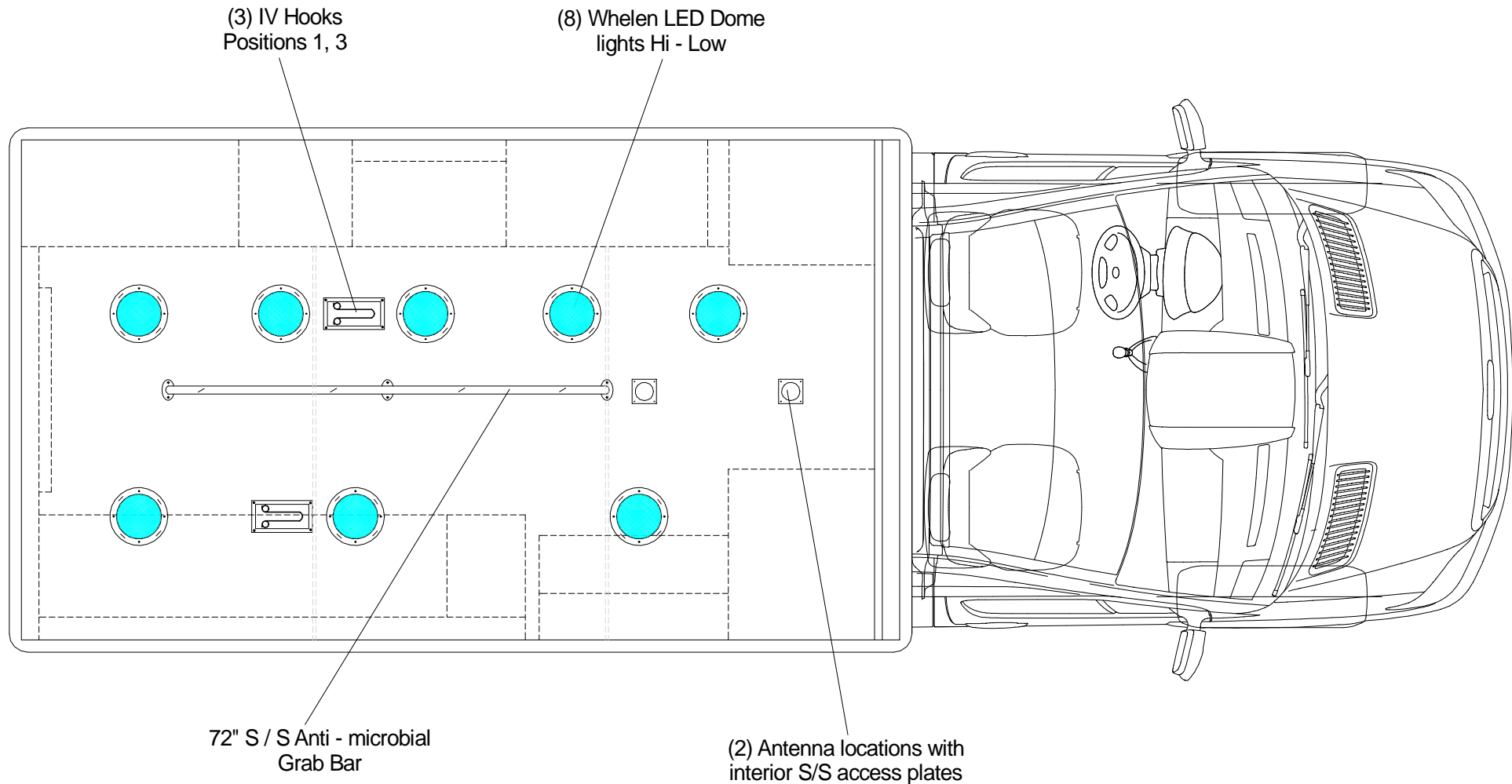

Note: All dimensions are approximate and subject to change.
10941 Weaver Ave., So. El Monte, CA 91733 phone. (626) 575-0880

VIEW: Cab Ceiling Interior

Drawn by: Jorge M.

LE- 13

